

Heavy-Duty Conductor Rail CopperHead



Release Date: 2021-01

Table of Contents

CopperHead Conductor Systems	4
Heavy-Duty Conductor Rails	4
Some Advantages of CopperHead Rail Systems	4
Product Pre-Selection	4
Technical Data	5
Voltage Drop Calculation.....	6
Possible Power Feed Locations	7
Example Voltage Drop Calculation	7
<hr/>	
System Components	9
Rails.....	10
F35 Rails F45 Rails Anchor Clamps.....	10
Rail Joints Rail Hangers	11
Power Feed Clamps ExpansionElements	12
Expansion Calculation.....	13
Insulation Joints	14
Current Collectors	15
<hr/>	
Replacement Parts and Tools	16
Carbon Shoe Collector SpareParts.....	16
General Spare Parts Mounting Material Tools Cable Lugs	16
<hr/>	
System Layout	17
Layout Schematic and Component Overview	18
Standard Installation Layout	19
Current Collector Arrangement.....	19
Installation Hints/Example.....	20
<hr/>	
Frequently Asked Questions	21
<hr/>	
Questionnaire	22

Heavy-Duty Conductor Rails



Aggressive environmental conditions and rough production processes require a durable and robust conductor rail system. The Conductix-Wampfler CopperHead Conductor System is a tried and tested conductor bar system designed for heavy-duty applications in rough environments, such as steel mills or ship yards. Non-insulated conductor rail systems are preferred for applications with higher ambient temperatures or temporary radiation heat, where insulated safety conductor rails are not always applicable.

The CopperHead Conductor System has several new design improvements compared to traditional CopperHead rail systems, and is in line with international standards for conductor rails. The standard rail length of 6 m reduces logistic costs and optimizes handling and installation. The improved joint technology and a production on an industrial level, supported by the Conductix-Wampfler quality insurance system, offer another customer benefit. Conductix-Wampfler as market leader in conductor rails and full line provider for energy and data supply systems is a proven partner for projects all over the world.

The CopperHead Conductor System is based on former non-insulated rails from Conductix-Wampfler (Delachaux, Bischoff & Hensel). Both "T" section with a span of 35/45 mm and the extruded CopperHead are drawn through a special die, which compresses the copper flanges around the dovetail head of the rail, connecting the two components to a 100% rigid unit. The CopperHead Conductor Rails represent a neat and compact arrangement and have proven an outstanding success for safe power feeding of various crane and transport applications. The CopperHead Conductor Rails are available in different sizes to meet individual current requirements up to 1860 Amps.

Some Advantages of CopperHead Rail Systems

With CopperHead-Systems you eliminate all drawbacks inherent in the conventional design of trolley wires, steel angles and steel rails. CopperHead Rails ensure an efficient and continuous contact.

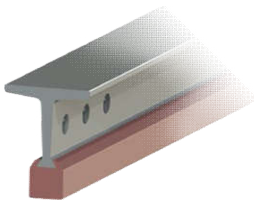

- Usable under higher ambient temperature conditions.
- Limited sparking effect by high contact performance.
- Easy maintenance by proven system design.
- Reduced down times through heavy duty.
- Long collector life times. Negligible wear – nearly unlimited life of conductors.
- Lower resistance between CopperHead and carbon bronze pick-up shoe.

Main applications are: steel mills, coking plants, gas works, cement industries, ship yards and dockside enterprises.

Steel CopperHead Rails are preferably used for applications in corrosive atmospheres and in locations with high humidity. The rails are supplied in 6 m (± 5 mm) standard lengths, drilled at either end for joint plates or expansion connectors. Shorter lengths are available to coincide with your run way lengths requirements. We produced a complete range of accessories, insulators and current collectors. Variation in temperature and resulting expansion and contraction is compensated by standard expansion joints. Adequate ampere capacity must be provided to carry the anticipated electrical loads: The total ampere load is determined from the nominal rated full load current reduced by the duty cycle and by a diversity factor for non-simultaneous operation.

Product Pre-Selection

Besides electrical parameters, environmental conditions and operating modes are important parameters for the product selection. The following overview will assist in the pre-selection. Further detailed information is listed under technical data.

Type	Industrial application – indoor or outdoor				
	Non-specific environment	Corrosive environment	Highly corrosive environment	Extremely corrosive environment – galvanic applications	Higher product safety
Steel-Copper Rail	++	++	+ 1)	+ 2)	+ 4)
Aluminum-Steel Rail (see alternative from Conductix-Wampfler)	++	++	–	–	+ 4)
Copper Rail ³⁾ * (see alternative from Conductix-Wampfler)	++	++	++	++	++

¹⁾ Surface protection needed (galvanized surface) ²⁾ Protective coating ³⁾ Insulated copper rails

⁴⁾ For non-insulated electrification systems, additional safety arrangements (installation height, distance, fences, etc.) according to local standards must be regarded

* For full copper rail version please contact Conductix-Wampfler Sales Support

CopperHead Conductor Systems

Technical Data

	35 mm		45 mm							
Rail Type	F35/50-6	F35/100-6	F45/50-6	F45/100-6	F45/150-6	F45/200-6	F45/300-6	F45/400-6	F45/500-6	F45/600-6
Current load at 100% duty cycle and 35°C [A]	410	529	495	620	728	826	1000	1156	1300	1440
Current load at 80% duty cycle and 35°C [A]	460	595	560	695	815	930	1120	1300	1455	1610
Current load at 60% duty cycle and 35°C [A]	530	685	645	800	940	1070	1290	1500	1680	1860
Conductor cross section (Copper) [mm ²]	50	100	50	100	150	200	300	400	500	600
Conductor cross section (Steel) [mm ²]	250		400							
Feed Span "b" [mm]	35		45							
Equivalent copper cross section [mm ²]	89	139	98	148	198	248	348	448	548	648
Rail height "H" [mm]	32.9	35.9	42.4	45.7	48	50.8	56	59.2	64.2	65.4
Head width "a" [mm]	13.5	15	14.1	15	17	17.2	17.5	19.8	19.8	22.8
Rail weight [kg/m]	2.39	2.84	3.75	4.2	4.64	5.08	5.98	6.89	7.54	8.46
Rail length [mm]	6000 ± 5									
DC resistance at 20°C [Ω/km]	0.204	0.130	0.17	0.119	0.089	0.072	0.051	0.040	0.032	0.027
Impedance at 50 Hz [Ω/km]	0.293	0.238	0.26	0.223	0.203	0.194	0.182	0.174	0.165	0.162
Nominal Voltage [V]	Depending on insulator type, rail spacing and local regulations									
Rated rail spacing [mm]	≥ 150									
Nominal suspension spacing [mm]	2500 [≥]									
System length	Unlimited (see expansion system)									
Expansion system	Segmented expansion unit (see expansion section)									
Environment	Indoor and protected outdoor applications									
Protection class	IP00									
Temperature range	-40 ... +200°C / -40 ... +266°F									
Storage temperature	-30°C ... +40°C / -22°F ... 104°F (dry to prevent oxidation, no condensation)									

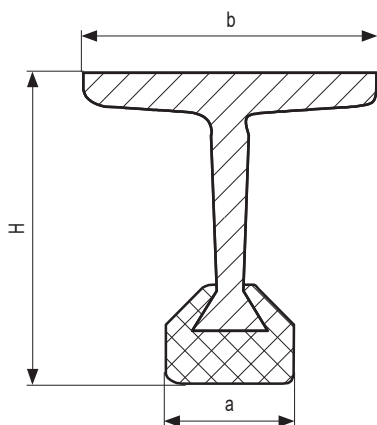

Standard range dimensions. For rails with higher amperage rates, please contact Conductix-Wampfler Sales Support.

Crane Electrification according to IEC 60204-32 Standard (2009 extract)



WARNING!

Danger
to life from
high voltage!

These European regulations are valid for electrical installations and electrical equipment in Europe and similar to several national standards in America, Australia and Asia. Electrical installations, such as conductor rail applications must be designed to avoid direct contact with live parts. The preferred solution is an insulated and monitored system. If this is not possible, e.g. high ambient temperature where insulation material not usable, the system must be installed that in operation and other situation can be used without a certain risk for any person. How to realize the needed safety please refer the valid regulations on-site and contact the local authority.

The operation of non insulated conductor rails and other electrical equipment above 48 V AC / 60 V DC without additional protection regarding local safety standards is not allowed. Electrical energy carries a high danger to life.

Voltage Drop Calculation

The maximum length between feeding point and freest consumer start up position are limited by the voltage drop and is depending of the installed drive system and start up consumption.

The position of the power feed can be designed at the first step by the onsite situation but must be checked by the voltage drop in the start up phase of the consumer. The voltage drop must be less than 5% or related to the customer specification. If the voltage drop exceed, the limit the rail cross section must be increased or the power feed in position and/or amount must be adapted.

After selecting the rail type based on the calculated total current depending on duty cycle and ambient temperature, the voltage drop must be checked. The calculated voltage drop must be under the value specified by the customer. Typical values here are 2-5% or 10% in exceptional cases. If the voltage drop is too high, the voltage might be too low to all the drives to start.

The following formulas are used for the calculation:

For direct current	$\Delta U_{35\text{ }^{\circ}\text{C}} = 2 \cdot l \cdot I_A \cdot R$ [V]	$\Delta U_{35\text{ }^{\circ}\text{C}}$ = voltage drop at 35 °C [V]
		I_A = total current [A]
For alternating current	$\Delta U_{35\text{ }^{\circ}\text{C}} = 2 \cdot l \cdot I_A \cdot Z \cdot \cos \varphi$ [V]	R = resistance of the conductor rail [Ω/m]
		Z = impedance of the conductor rail [Ω/m]
For three-phase power	$\Delta U_{35\text{ }^{\circ}\text{C}} = \sqrt{3} \cdot l \cdot I_A \cdot Z \cdot \cos \varphi$ [V]	l = feed length [m]
		$\cos \varphi$ = phase distance angle

Note: I_A here is the portion of the load current "drawn" during start-up. ($I_A = I_B + I_{A'}$)

This consists of the basic load I_B , like lighting and air conditioners, and the start-up currents of the drives $I_{A'}$.

For start-up current, the following applies:

Three-phase asynchronous drive in direct start:	$I_{A'} = I_N \times 5$ to 6 (up to max. 21 kW permitted)	I_A = total current = $I_B + I_{A'}$
Slip ring rotor motor:	$I_{A'} = I_N \times 3$ to 5	$I_{A'}$ = total current when starting I_N = Nominal Engine Current
Frequency converter:	$I_{A'} = I_N \times 1.2$ to 1.4	

CopperHead Conductor Systems

Possible Power Feed Locations

The power feed arrangement must be appropriate for the specific case, since the voltage drop is calculated with the feed length "l" that falls between the power feed and the end of the conductor rail. The following power feed options are normally used:

End power feed

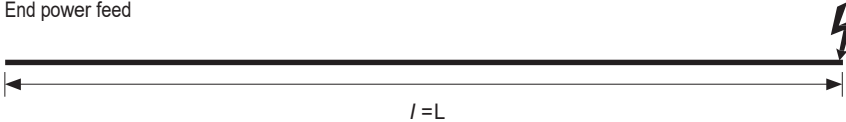

$l = L$ With an end power feed

Middle power feed

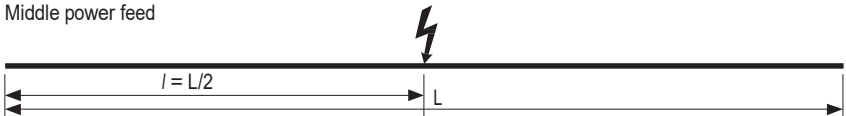

$l = L/2$ With a middle power feed

$l = L/4$ For two power feeds at both ends

Power feed on both sides

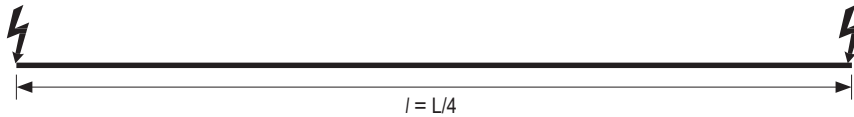

$l = L/6$ For two power feeds each L/6 from the ends

$l = L/10$ For a power feed in the middle and L/10 from each end

$l = L/14$ For four power feed points

L = length of the conductor rail [m]

L/6 powerfeed

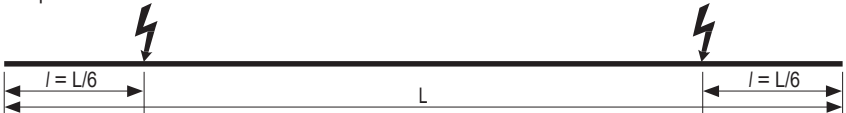

L/10 powerfeed

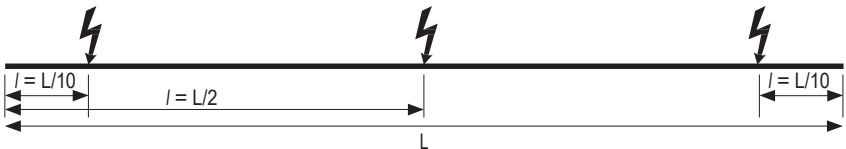

L/14 powerfeed

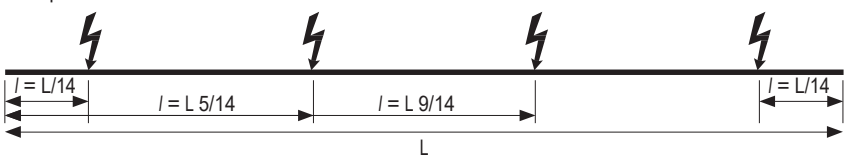

Example Voltage Drop Calculation

The average crane motor duty cycle is usually between 40% and 60%, depending on the type of application. A diversity factor of 0.4 to 0.7 can be mostly used when there is more than one crane on the same runway. Example:

Start up current

- 1 crane, $I = 500$ Amps. (50 Amp auxiliary consumers 450 A drive and lift motor consumption)
- Power supply 690 V AC, 3-phase
- Length of runway: 100 m (330 ft.)
- Typical crane duty cycle: 60% (ED)
- Assumed diversity factor: 0.7 per crane (hoist, trolley gantry)

- Converter drive System Start up factor: 1,3
Ampere load crane = $50 \text{ A} + (450 \text{ A} \times 0.7) = 50 \text{ A} + 315 \text{ A}$
Start up Current System = $50 \text{ A} + 315 \text{ A} \times 1.3 = I_G = 460 \text{ A}$
- Total ampere load when starting: 460 A
- Selected conductors: F35/100 OR F45/50
- Voltage drop $\Delta U = 5\% \times 690 = 34.5 \text{ V}$
- Feed length $l = \Delta U_{35^\circ\text{C}} / (\sqrt{3} \cdot I_G \cdot Z) = 194 \text{ m}$
- Selected power feed location: End power feed.



CopperHead Conductor Systems Components

The System Components

CopperHead conductor rails are based on the combination of universally applicable standard components. Design, length and material are optimized to fulfill the requirements in logistic, installation, operation and maintenance of steel mills and similar rough crane indoor and protected outdoor applications.

The components:

- CopperHead rails with rigid steel base for rough environments where aluminum or fully insulated rails reach their limits
- Easy to use rail joints
- Hanger clamps with insulators to hold the rail in position and insulate it from the base steel structure
- Anchor clamps to mount the rail against movement to the structure
- Massive power feed elements with low resistance and solid build for the cable connection on-site
- Expansion joints for length compensation
- Air insulation elements for rail segmentation, e.g. maintenance segment

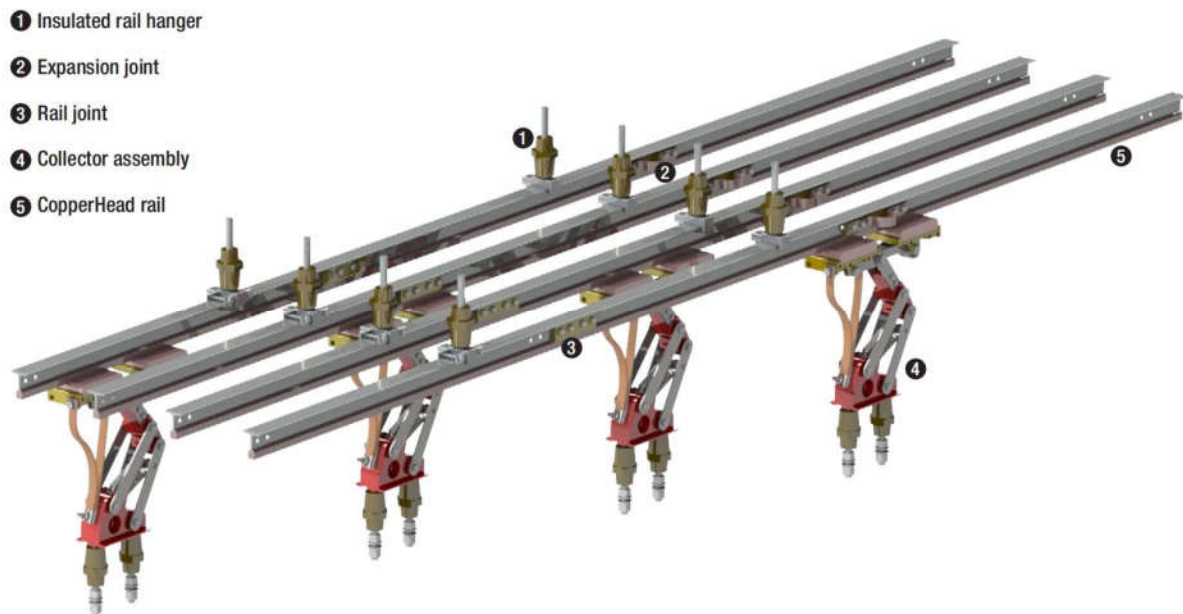

The Conductix-Wampfler CopperHead rail is steel-based and in accordance with the international standard design of non-insulated rail systems for crane applications. The efficiently sized 6 m rail reduces logistic costs and allows for easy installation and distribution of the system. This length is conforming to the international standard length for steel profiles and is compatible with handling/transport and storage equipment. Shorter rail segments can be easily cut on-site with standard equipment. Individual rail lengths are available on request, subject to minimum order lot size.

System Arrangement and Interface to the Building/Crane Structure on-site

The interface to the structure on-site is a typical system integration engineering task and can be offered as engineering service from our local sales and service subsidiary or partners. Please contact your local Conductix-Wampfler sales and service (see www.conductix.com for contact information).

Hanger distance, type of insulator, installation height, access distance and other design aspects are depending on the supply voltage level and the local electrical and safety regulations. In addition to national regulations often end customer safety specifications have to be taken observed.

Non insulated rails carry a higher risk for material damage and danger to life and require additional on-site safety precautions.

For details refer to local standards or to the responsible authority on-site.

Rails

- Standard length: 6m +/- 5mm
- Installation position: horizontal or lateral installation setup
- Base: pure/galvanized
- Head: massive electrical copper

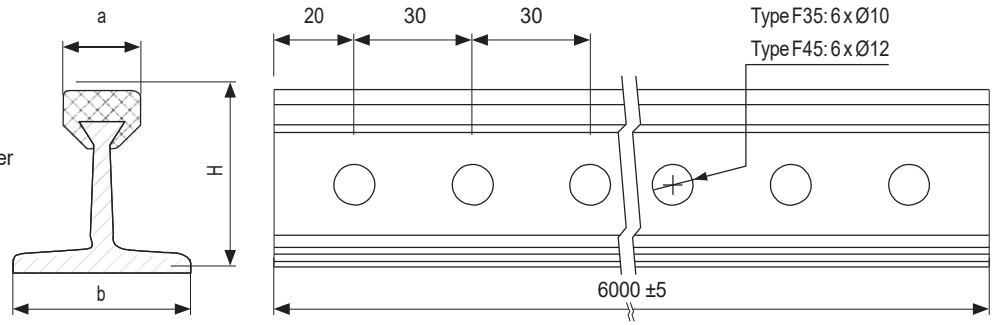
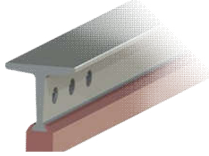

F35 Rails

Rail Type	Order No.	Base	Max. continuous 100% DC/ 60% DC [A]	Copper cross section [mm ²]	Steel cross section [mm ²]	H [mm]	a [mm]	b [mm]	Cu weight kg/6 m	Rail weight kg/6 m	Price
F35/50-6	801R268	galvanized	410/530	50	248.5	32.9	13.5	35	2.69	14.34	
F35/100-6	801R368	galvanized	529/685	100	248.5	35.9	15	35	5.34	17.04	

F45 Rails

Rail Type	Order No.	Base	Max. continuous 100% DC/ 60% DC [A]	Copper cross section [mm ²]	Steel cross section [mm ²]	H [mm]	a [mm]	b [mm]	Cu weight kg/6 m	Rail weight kg/6 m	Price
F45/50-6	801R468	galvanized	495/645	50	400	42.6	14.1	45	2.69	22.5	
F45/100-6	801R568	galvanized	620/800	100	400	45.7	15	45	5.34	25.2	
F45/150-6	801R668	galvanized	728/940	150	400	48	17	45	8.05	27.84	
F45/200-6	801R768	galvanized	826/1070	200	400	50.8	17.2	45	10.65	30.48	
F45/300-6	801R868	galvanized	1000/1290	300	400	56	17.5	45	16.02	34.08	
F45/400-6	801R968	galvanized	1156/1500	400	400	59.2	19.8	45	21.34	41.16	
F45/500-6	801R558	galvanized	1300/1680	500	400	64.2	19.8	45	26.58	45.27	
F45/600-6	801R658	galvanized	1440/1860	600	400	65.4	23	45	32.064	50.76	

CopperHead Conductor Systems

Components

Anchor Clamps

- Anchor to hold the rail in position
- Material: steel
- Installation torque: 25 Nm
- Amount for rail and fixing point = 2 pieces
- Content of delivery: hanger with fasteners

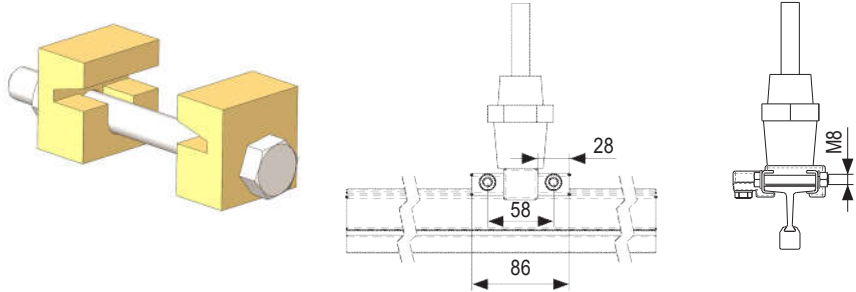

Type	Order No.	Description	Weight [kg]	Price
35	801R121	Rail anchor for rail hanger F35 type	0.065	
45	801R122	Rail anchor for rail hanger F45 type	0.072	

Rail Joints

- Rail connector device incl. mounting material
- Material: brass
- Installation torque: 25 Nm
- Content of delivery: joints with fasteners

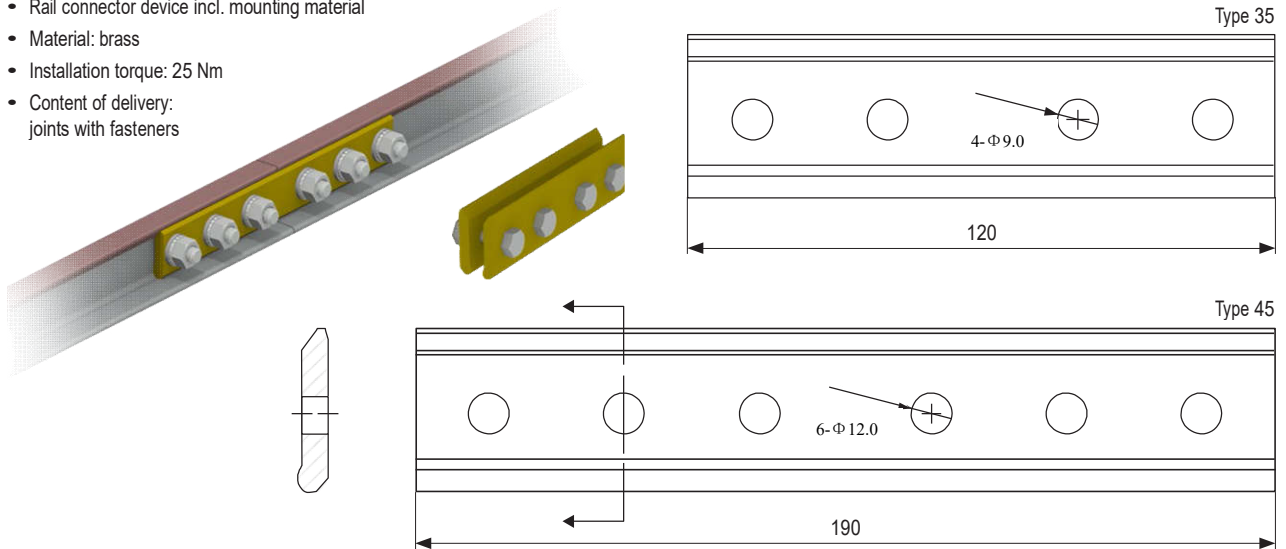

Type	Order No.	Description	Rail Matching	Weight [kg]	Price
35	801R111	Rail joint F35 rail ASSY	All F35 rails	0.116	
45	801R211	Rail joint F 45 rail ASSY	F45/50~300	0.19	
45	801R311	Rail joint F 45-2mm rail ASSY	F45/400~600	0.66	
-	310932	Joint compound (for approx. 30 joints)	---	0.03	

Rail Hangers

- Rail hanger
- Material: steel
- Installation torque: 25 Nm
- Max. hanger distance: 2500 mm
- Max. insulator voltage: 1kV (higher voltage on request)
- Temperature range: -40°C (-40°F)... +130°C (266°F) (higher temperature range on request)
- Insulator for indoor and protected outdoor installation
- Included in delivery

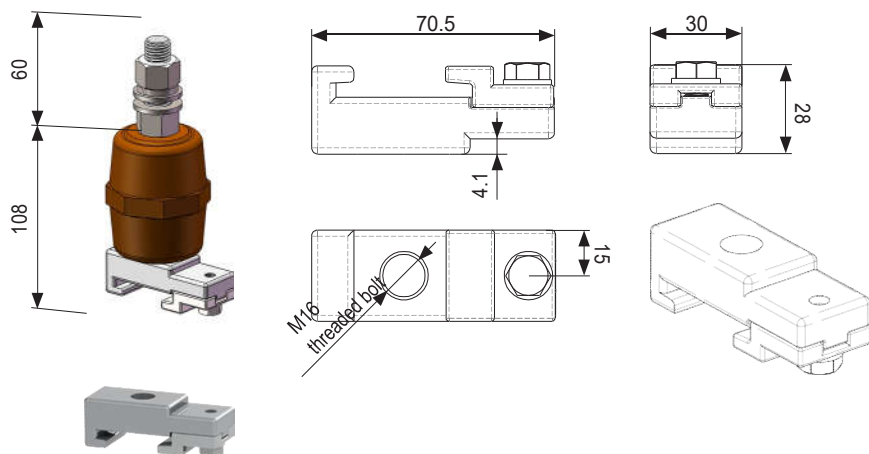

Type	Order No.	Description	Insulator	Weight [kg]	Price
35	801R182	Rail hanger for F35 rails	Yes	0.56	
35	801R183		No	0.32	
45	801R282	Rail hanger for F 45 rails	Yes	0.61	
45	801R283		No	0.37	

CopperHead Conductor Systems Components

Power Feed Clamps

- For power feed cable connection
- Material: copper, brass
- Installation torque: 25 Nm
- Max. cable cross section: 630 mm²
- Max. bolt size: M8 x 40 mm
- Content of delivery: power feed plate, joints and fasteners

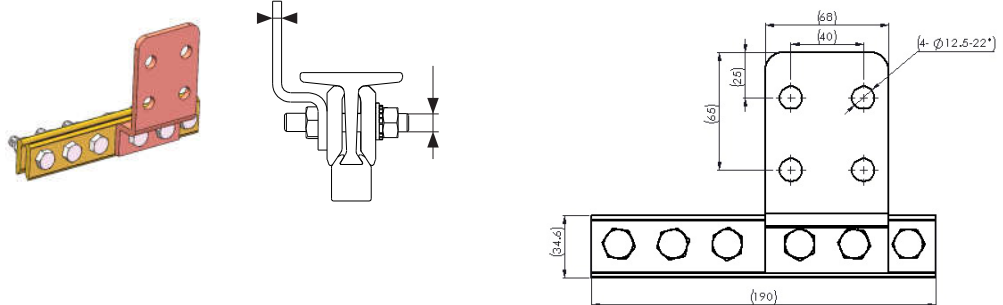

Type	Order No.	Description	Rail Matching	Weight [kg]	Price
35	801R151	Power feed clamp for F35 rail type	All F35 Rail	0.49	
45	801R152	Power feed clamp for F45 rail type	F45/50-400	0.51	
45	801R153	Power feed clamp for F45 rail type	F45/500-600	1.6	

*Ø 12.5 pre drilled factory, bigger diameters can be enlarged on-site (max. 22 mm)

Expansion Elements

- Length compensation element
- Material: copper + brass
- Installation torque: 25 Nm

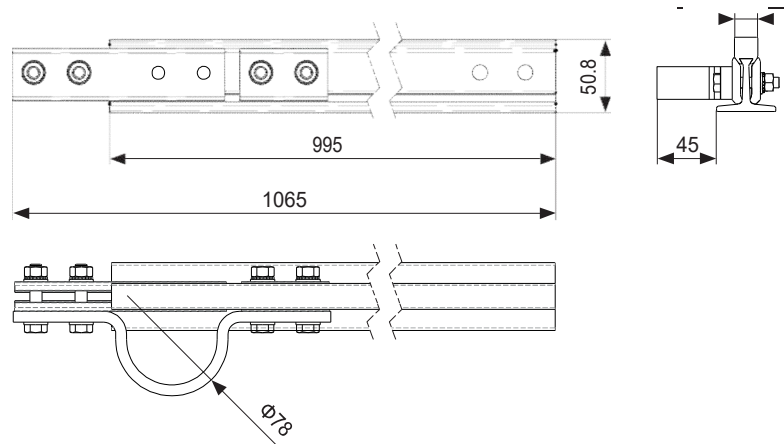
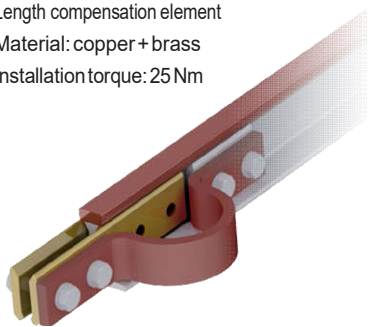

The expansion element is installed instead of a rail joint.
The expansion elements includes: expansion bar, joint, short joint, copper strip, screws, washers, nuts.

Type	Order No.	Description	Expansion way [mm]	Material	Weight [kg]	Price
35-50	801R260	Expansion ASSY 50 mm ² for 35-50 (with galvanization)	58	Copper, Brass	3.1	
35-100	801R360	Expansion ASSY 100 mm ² for 35-100 (with galvanization)		Copper, Brass	3.7	
45-50	801R460	Expansion ASSY 50 mm ² for 45-50 (with galvanization)		Copper, Brass	4.1	
45-100	801R560	Expansion ASSY 100 mm ² for 45-100 (with galvanization)		Copper, Brass	4.5	
45-150	801R660	Expansion ASSY 150 mm ² for 45-150 (with galvanization)		Copper, Brass	5.1	
45-200	801R760	Expansion ASSY 200 mm ² for 45-200 (with galvanization)		Copper, Brass	5.5	
45-300	801R860	Expansion ASSY 300 mm ² for 45-300 (with galvanization)		Copper, Brass	6.5	
45-400	801R960	Expansion ASSY 400 mm ² for 45-400 (with galvanization)		Copper, Brass	7.5	
45-500	801R572	Expansion ASSY 500 mm ² for 45-500 (with galvanization)		Copper, Brass	9.6	
45-600	801R672	Expansion ASSY 600 mm ² for 45-600 (with galvanization)		Copper, Brass	11.3	

Expansion Calculation

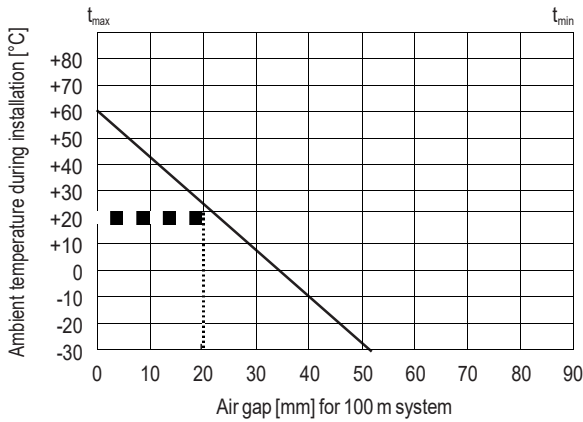

Legend:

- t_{min} lowest temperature that occurs in the application
- t_{max} highest possible working temperature in the application

Example:

- Temperature range: from 0 °C to +25 °C
- Ambient temperature during installation: +25 °C
- Steel rail air gap: 19 mm

The chart shows orientation lines for the conductor rail, considering 100 m expansion joint intervals. For gap setting move the orientation line in parallel up to the point presenting the anticipated max ambient temperature. Then connect point of actual ambient temperature during installation to the right until intersecting with the orientation line. Follow the vertical axis downward to read the air gap dimension in mm.

For installation above 100 m the amount and position of the expansions will be engineered based on the application input individual.

The rail system is mainly installed on a steel or concrete structure. The thermal expansion of the rail and this structure are very close and theoretical no expansion are needed by changes of the ambient temperature. In application with local high temperature effects and temperature changing or longer installation above 100 m system length a expansion unit are recommended. At expansion on building and structure side also a expansion on the rail system are needed corresponding with the building expansion section. For installation above 100 m the amount and position of the expansions will be engineered based on the application input individual.

Please contact our Technical / Sales Support if you need any support with the calculation.

$$\Delta t_{ges} = \Delta t_U + \Delta t_{sw}$$

Δt_U = Temperature range of the ambient temperature

Δt_{sw} = Temperature increase due to electric current (electrical thermal load)

Recommended values for Δt_{sw} :

10 °C up to 40% duty cycle

20 °C up to 65% duty cycle

30 °C up to 100% duty cycle

For longer systems than those in the table above, use:

$$\frac{L - 100}{a} = \text{number of Expansion Units (L: system length, a: expansion way)}$$

Connect the rails by rigid or expansion joints using the holes provided at the ends of the 6 m sections. For systems up to 100 m no expansion joints required. With longer runs use an expansion joint after every 6 standard lengths of 6 m intervals. For special heat environment and strong temperature fluctuations reduce these intervals to 28 m. For gap setting see adjacent diagram and example. Provide an extra insulator/Rail support close to each expansion joint – approx. 250 mm.

CopperHead Conductor Systems

Components

Insulation Joints

- Rail insulation segment to separate the rail track in segments
- Material: PTFE
- Max. Voltage: 1000 V/7000V
- Installation torque: 25 Nm
- Air distance: 60/180 mm
- Content of delivery: insulation elements, fasteners

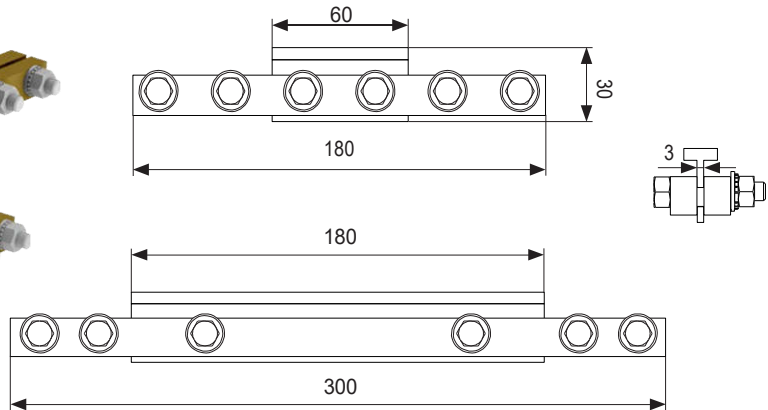
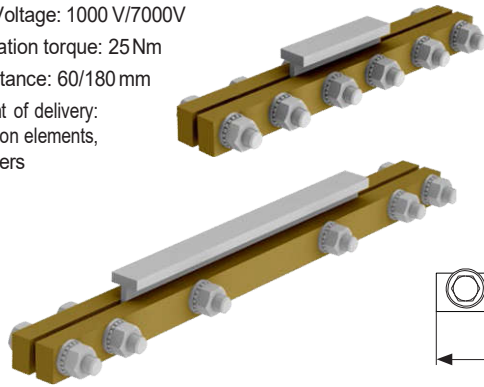

Type	Description	Order No. (for Gap length 60 mm) 1000V	Price	Weight [kg]	Order No. (for Gap length 180 mm) 7000V	Price	Weight [kg]
35/50	Insulation Joint for CopperHead rail 35-50	801R237		0.329	801R238		0.422
35/100	Insulation Joint for CopperHead rail 35-100	801R337		0.335	801R338		0.428
45/50	Insulation Joint for CopperHead rail 45-50	801R437		0.451	801R438		0.634
45/100	Insulation Joint for CopperHead rail 45-100	801R537		0.456	801R538		0.648
45/150	Insulation Joint for CopperHead rail 45-150	801R637		0.462	801R638		0.667
45/200	Insulation Joint for CopperHead rail 45-200	801R737		0.469	801R738		0.688
45/300	Insulation Joint for CopperHead rail 45-300	801R837		0.481	801R838		0.724
45/400	Insulation Joint for CopperHead rail 45-400	801R937		0.496	801R938		0.769
45/500	Insulation Joint for CopperHead rail 45-500	801R526		0.429	801R528		0.773
45/600	Insulation Joint for CopperHead rail 45-600	801R626		0.579	801R628		0.813

Current Collectors

- Current collector: max. 450 A / 900 A
- Max. voltage: 690V / 3kV
(*higher voltage on request)
- Temperature range: -40°C (-40°F) ... +130°C (266°F)
(higher temperature range on request)
- Material: steel, copper, plastic
- Collector brush: carbon-bronze
- Content of delivery: collectors, frame, copper belt, insulator, fasteners

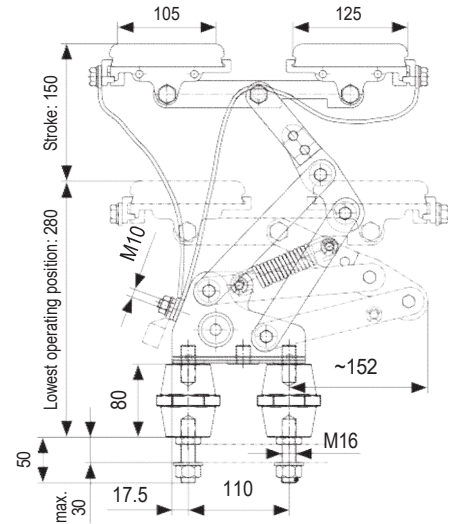
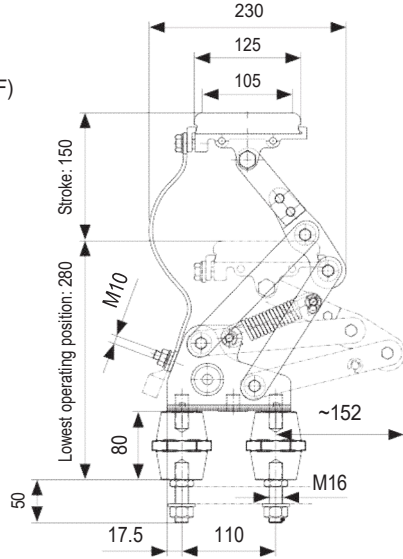
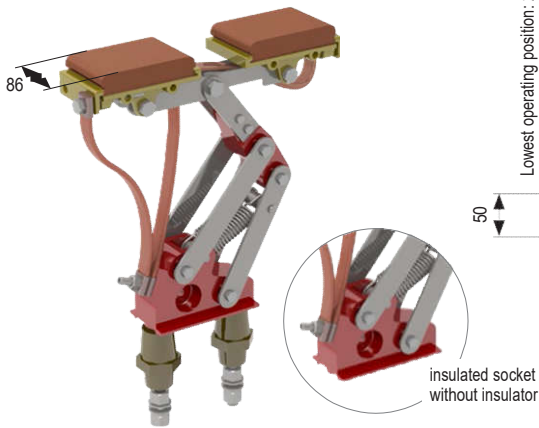

Type	Order No.	Description	Voltage [V]	Operation height [mm]	Nom. Current [A]	Weight [kg]	Price
Single	394176	Single shoe collector with insulated socket	≤ 690	275	450	20.6	
Single	801R177	Single shoe collector with insulated socket + insulator	≤ 3000	355	450	22.2	
Double	394196	Double shoe collector with insulated socket	≤ 690	275	900	26.7	
Double	801R197	Double shoe collector with insulated socket + insulator	≤ 3000	355	900	28.2	

CopperHead Conductor Systems

Replacement Parts and Tools

Carbon Shoe / Collector Spare Parts

System performance requires the optimized material and original spare parts to prevent breakdowns and ensure durability. Copies and non-conform spare parts can increase rail wear.

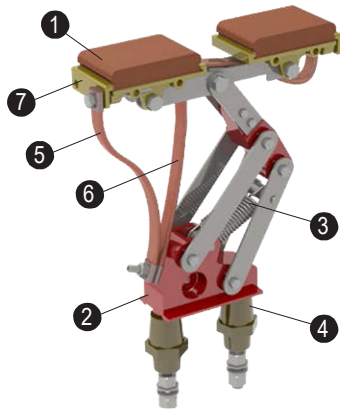

Type	Order No.	Description	Weight [kg]
1	393401	Spare brush 450 A	2.15
2	395041	Mounting set for spare brush	0.476
3	935405	Collector spring (set)	0.11
4	801R420	Insulator	0.7
5	944005	Connecting strand	0.61
6	944008	Connecting strand	0.71
7	393702	Shoe holder	1.8

Bracket

Item	Order No.	Description	Unit	Weight [kg]
1	W80321	Standard Rail Hanger Bracket	Pcs.	10.8
2	W80173	Standard Collector Bracket	Pcs.	0.1

*Solution will be made with standard bracket, customized design of brackets upon request.

Cable Lugs

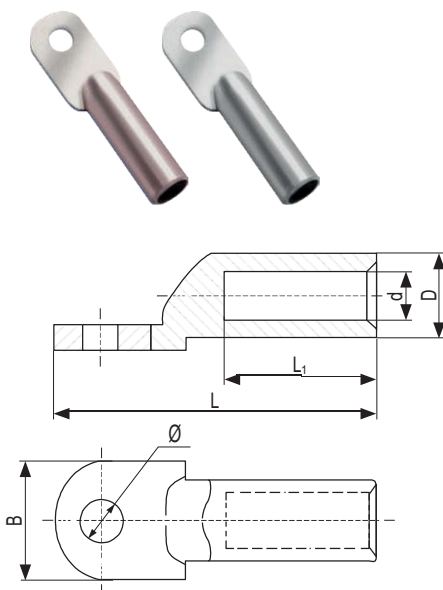

Type	Order No.	Cable cross section [mm ²]	Dimensions [mm]					
			ø	D	d	L	L1	B
DT-50	DTS-50	50	10.5	14	9.5	85	38	23
DT-70	DTS-70	70	12.5	16	11.5	95	43	26
DT-95	DTS-95	95	12.5	18	13.5	104	46	28
DT-120	DTS-120	120	14.5	20	15	112	49	30
DT-150	DTS-150	150	14.5	22	16.5	120	51	34
DT-185	DTS-185	185	16.5	25	18.5	125	55	37
DT-240	DTS-240	240	16.5	27	21	136	60	40
DT-300	DTS-300	300	18	31	23.5	155	66	50
DT-400	DTS-400	400	21	34	26.5	170	75	50
DT-500	DTS-500	500	21	38	29	190	75	60
DT-630	DTS-630	630	21	45	35	220	85	80
DT-800	DTS-800	800	21	50	38	260	85	100

CopperHead Conductor Systems

System Layout

System Layout

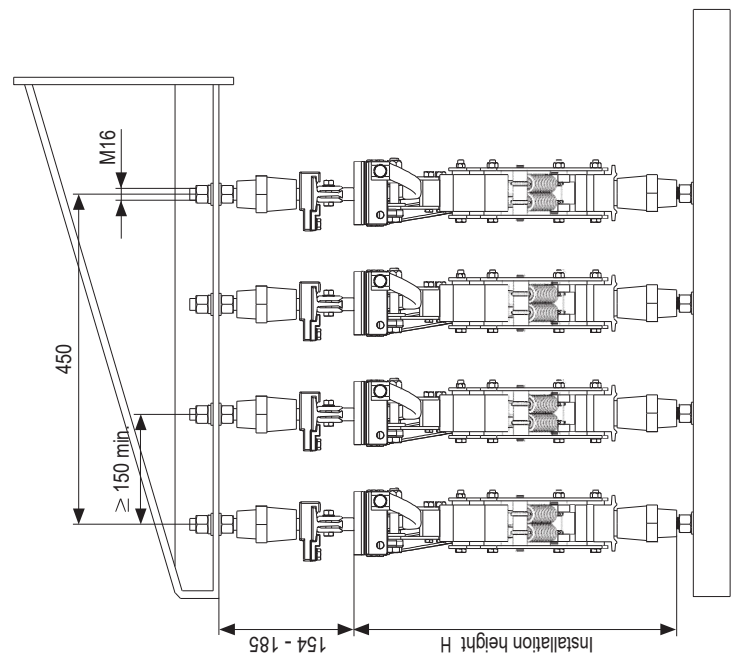
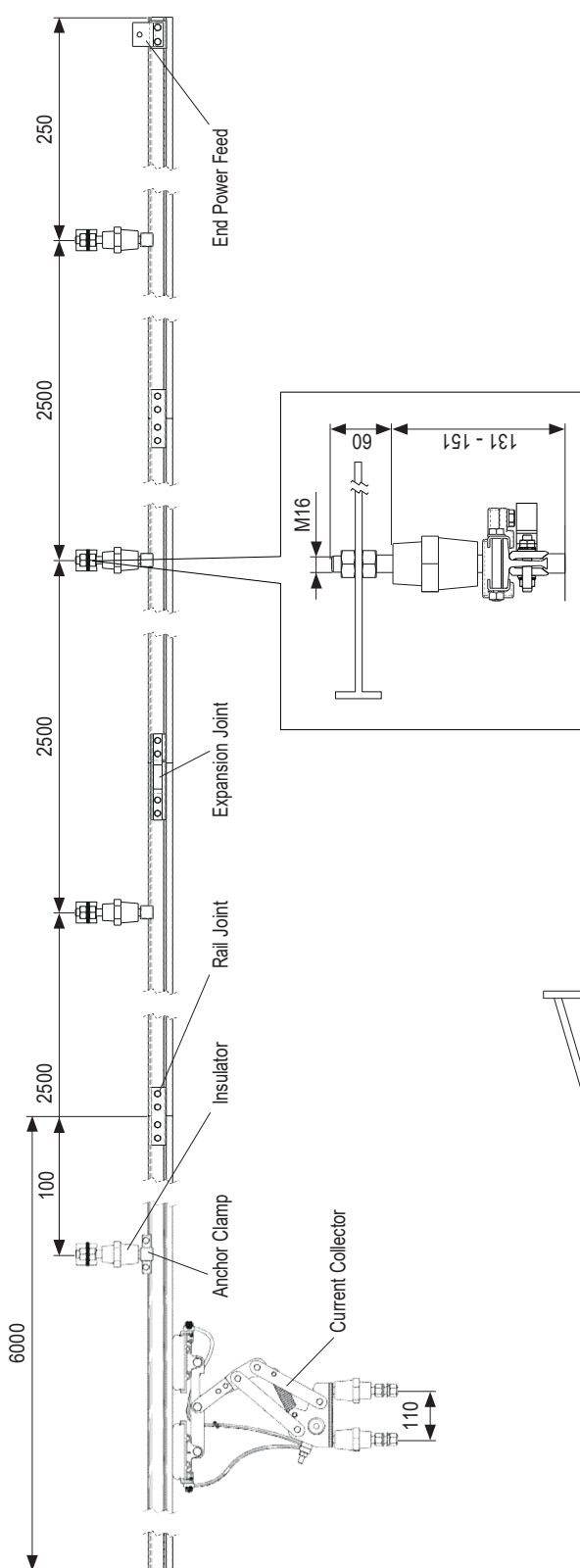

Rail Hanger Offset
 We recommend installing the rails in a Zigzag manner to prevent irregular brush wear.
 Rail offset is ± 15 mm.

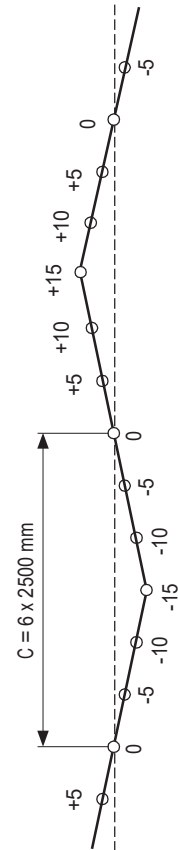

Collector assy type	394176	801R177	394196	801R197	801R178	801R198
H(mm)	275 ± 25	355 ± 25	275 ± 25	355 ± 25	260 ± 25	260 ± 25

CopperHead Conductor Systems

System Layout

Layout Schematic and Component Overview

Example: 100 m steel rail system

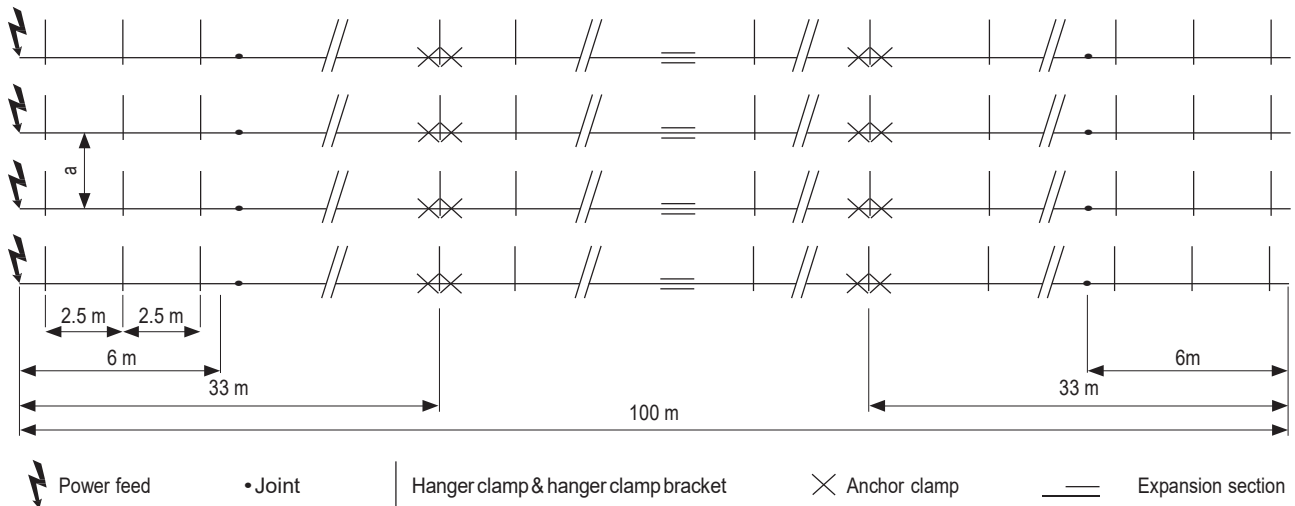

Installation note

Regarding the first and the last conductor rail a support distance of 1750 and 250 mm from the beginning resp. the end of the rail is to be provided. Apart from that the support spacing is 2.5 m. The earth collector should always be installed on the outside. The centre distance between two conductors can be taken from the table below.

Distance between centers	Standard voltage arrangement	High voltage arrangement
Minimum distance a	≥ 150	$> 250^*$

* consider local regulations

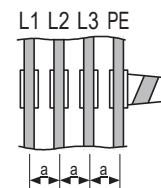

Example material overview

Here is a typical crane conductor rail system that is 57 m in total length, with 4 poles, 800 A, with all accessories, Current collectors and support arms. The required Bill of Materials is listed below. The order quantity should be increased by an assembly reserve for the parts marked with an (X).

Part Description	Order No.	Quantity Needed
Conductor rail 6 m long	801R767 6mX36	36
Conductor rail 2 m long	801R767 2mX4	4
Hanger clamp	801R282	80 (X)
Anchor clamp	801R122	8 (X)
Power feed	801R152	4 (X)
45 Joint ASSY	801R211	36 (X)

CopperHead Conductor Systems

System Layout

Standard Installation Layout

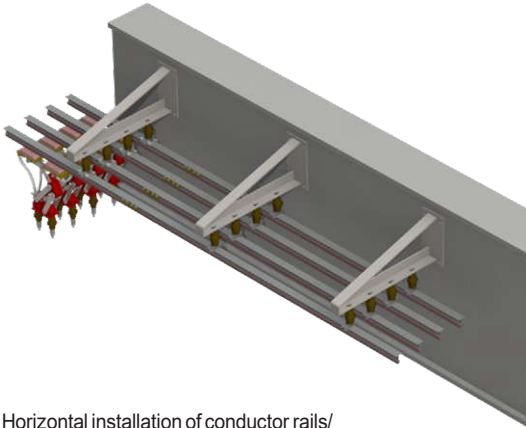

Horizontal installation of conductor rails/
Vertical insertion of Current Collectors

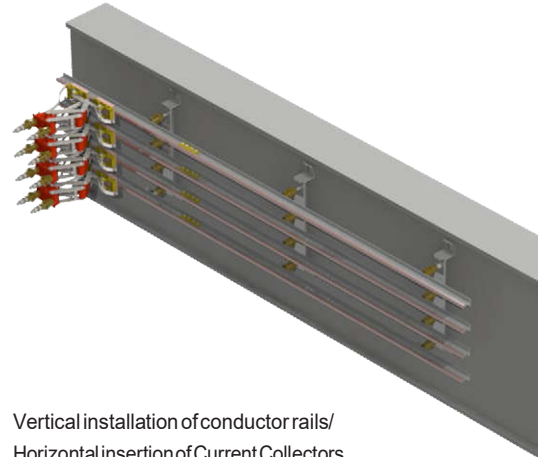

Vertical installation of conductor rails/
Horizontal insertion of Current Collectors

Current Collector Arrangement/Hanger Distance

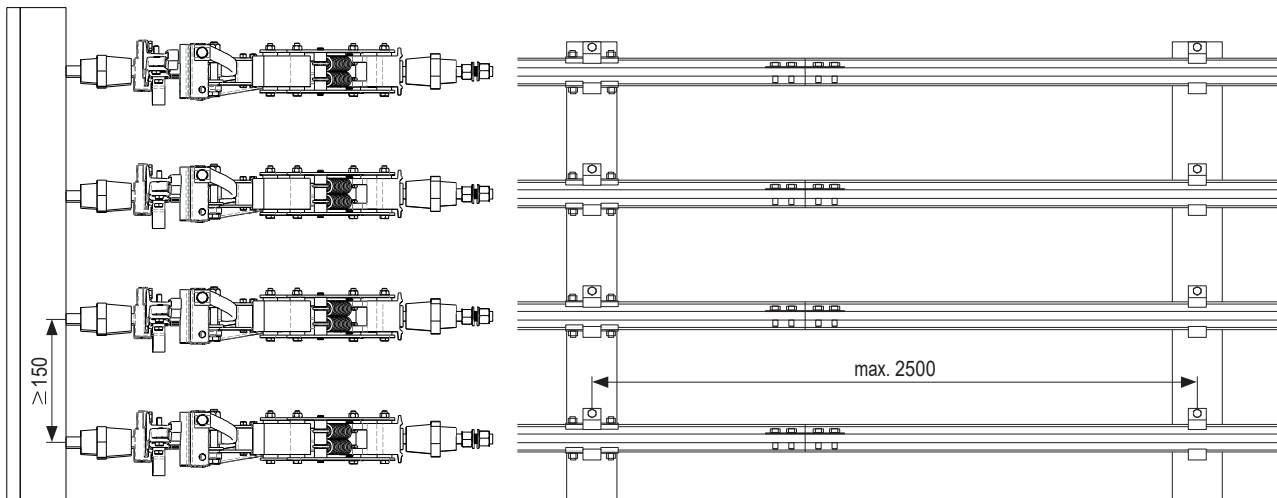

For installations without transfer points the current collectors for vertical and horizontal can be staggered.
This way the centre distance between two conductor rails is reduced by 10 mm.

Distance between centers of two conductor rails	Standard current collector arrangement	Offset Current Collector arrangement
Minimum distance a [mm]	150	250*

* consider local regulations

Installation note

Please note that the centre line of the current collector is mounted to the centre line of the conductor rail. The distance between towing arm and conductor rail must be set according to above table and sketches.

Please choose phase distances in accordance with local regulations and voltage levels on-site.

CopperHead Conductor Systems

System Layout

Installation Hints – Example

Phase distance “A”

The phase distance must be designed regarding application requirements and regulations on-site. Technical minimum: A = 150 mm.

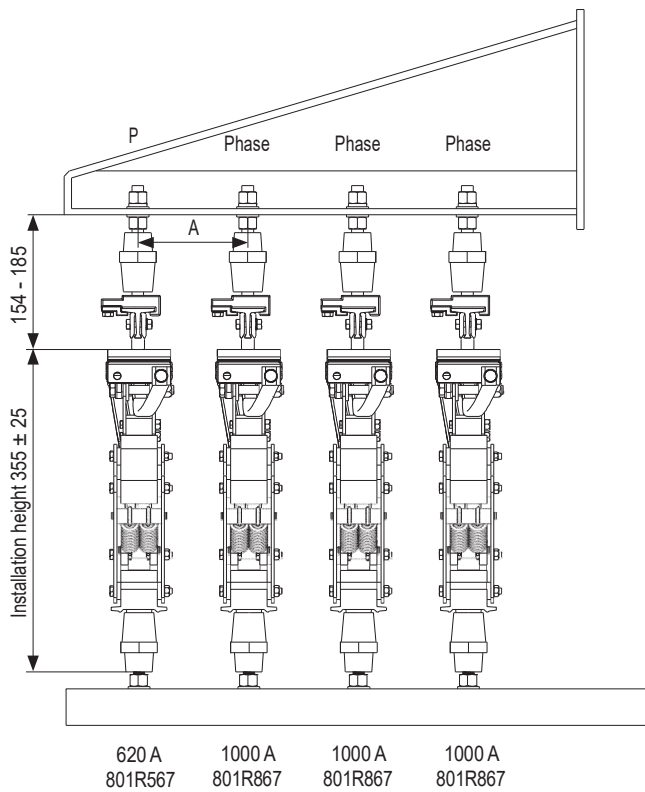

Note:

- PE can be reduced by 50% cross section.
- Please choose phase distances in accordance with local regulations and voltage levels on-site.

Zigzag Layout

We recommend installing the rails in a Zigzag manner to prevent irregular brush wear.

Rail offset is ± 15 mm.

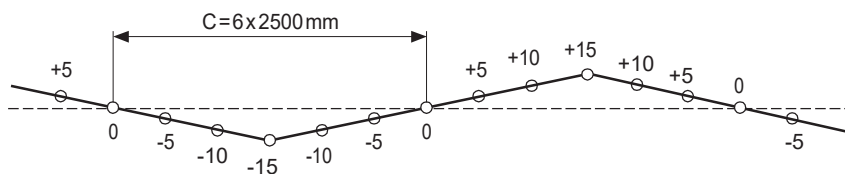

CopperHead Conductor Systems

FAQ

Does Conductix-Wamplfer offer Engineering and Installation Services?

Conductix-Wamplfer is the leading global represented partner for Energy and Data Transmission systems and offers, besides a large portfolio of solutions, installation and service support.

How can we Manage System Lengths not dividable by 6 m Rail Length?

The rail can be simply cut to length on-site. Bigger volumes of short lengths are also available from factory side on request.

What kind of Power Feed Configuration is preferred?

The power feed arrangement depends on the installation, load and rail cross-section. The voltage drop calculation is used to check if the crane can start up in the end position under starting conditions. Is the voltage drop too high (typical values 2-5%) the cross-section must be increased or the active length between power feed and crane end position must be reduced (use of center power feed or multiple power feed design.)

Why use Joint Compound at the Joints?

The compound, which is applied to all contact surfaces of the joint, prevents contact corrosion and keeps humidity from entering in between parts. Corrosion increases resistance and reduces the product performance.

What are the recommended Phase Distances between two Rails?

The distance between two phases depends on the used power voltage level, dust and humidity on-site and local regulations to prevent short circuit risks by low air creepage values.

What is the maximum Short Circuit Current?

The maximum short circuit request is coming from busbar installations (rail between two stationary units, e.g. transformers). The aim is for the system to be switched back automatically in operation without damage to any parts caused by the short circuit incident. With flexible power feeds and current collectors this requirement cannot be met in any case. Power feed and collectors are not rigid enough to resist the electromagnetic field and forces. The short circuit values for the rail system itself are available on request and depend on hanger and phase spacing as well as the type of short circuit incident (AC or DC, between two phases or phase/ground).

Are the Impedance and Resistance Values at other temperatures and 60 Hz available?

The impedance and resistance values are listed in the technical data and are measured at 35° C ambient temperature and 50 Hz. The change in temperature and a frequency with 60 Hz are very low and close to the listed values.

Questionnaire CopperHead Conductor Rails



If you would like us to make you an offer, please fill out the following information: If you have any questions please do not hesitate to contact a sales representative.

General Project Information

Configuration

35 mm Railway CopperHead		
Pole	410 A	529 A
1		
2		
3		
N		
PE		

45 mm Railway CopperHead							
Pole	495 A	620 A	728 A	826 A	1000 A	1156 A	
1							
2							
3							
N							
PE							

Length: _____ m

Length: _____ m

Environmental Temperature Range _____ °C to _____ °C

Electrical Parameters

- Operational voltage 3 Ph 400 V AC

- Supply frequency 50 Hz 60 Hz
- Average current _____ A Peak current _____ A
- Drive performance per crane _____ kW
- Max. permissible voltage drop 5% _____ %
 _____ V

Power Feed

- 1 x system power feed
- _____ x system power feeds

Assembly Performed

- by Customer
- by Conductix-Wampfler Service

Additional Information

Customer Data

Company _____ Customer-No.: _____

FAO: _____

Address: _____

Phone: _____ Fax: _____

E-Mail: _____

Your Applications – Our Solutions

Conductor rails are just one component of the many solutions from the broad spectrum of Conductix-Wampfler energy, data, and handling systems. Which solution is the right one for your application always depends on the specific application situation. A combination of multiple Conductix-Wampfler products often provides very attractive advantages. Consulting and engineering competence are at your command in our companies and representatives around the world – as well as our solutions!



Cable reels

Motorized and spring cable reels from Conductix-Wampfler have their place wherever energy, data and media must travel a wide variety of distances in a short time – in any direction, quickly and safely.



Festoon systems

Conductix-Wampfler festoon systems are a fixed part of any industrial application: reliable and robust and available in an enormous variety of dimensions and variants.



Conductor rails

Whether they're a box conductor rail or an extendible single-pole system, familiar Conductix-Wampfler conductor rails get people and material moving reliably.



Non-insulated conductor rails

Extremely robust, non-insulated conductor rails with copper head or stainless steel support surface are the ideal basis for harsh use e.g. in steel plants or ports.



Energy chains

The jack-of-all-trades when it comes to energy, data and media transfer. With the breadth of their product range, energy chains have a permanent place in industrial applications.



Slip ring bodies

Wherever things have to be smooth and round, tried and trusted slip ring bodies from Conductix-Wampfler provide interruption-free energy and data transmission. The focus here is on flexibility and reliability!



Inductive Power Transfer IPT®

The contact-free system for energy and data transmission. For high speeds absolutely free of wear.



Take-up reels and spring balancers

Whether for hoses or cables, as classic take-up reel or high-precision positioning aids for tools – take-up reels and spring balancers from Conductix-Wampfler take the load off you.



Jib booms

Installed with tool transporters, trolleys or complete media feed – safety and flexibility are brought together here when handling tough tasks.



Conveyor systems

Whether manual, semiautomatic or with Power & Free – a high degree of individuality is guaranteed when it comes to layout requirements and the place of use.

www.conductix.com

Conductix-Wampfler has just one critical mission: To provide you with energy and data transmission systems that will keep your operations up and running 24/7/365.

To see how we can help you, contact us at www.conductix.com

